

Chubb safes proudly presents the Chatwood Certified Series. Three levels of high security safes offering certified protection against concentrated burglary attacks utilizing sophisticated torches, tools and explosives.

These features, along with certified fire protection, ensure unparalleled protection for your valuables.



Model VI-6628EX



Chatwood Certified Series

HIGH SECURITY BURGLARY, EXPLOSIVE AND FIRE PROTECTION SAFES

Series 4000 / ECB•S Grade IV Safes

(Comparable to the overall security of UL listed TRTL-15x6 safes)

Series 5000 / ECB•S Grade V Safes

(Comparable to the overall security of UL listed TRTL-30x6 safes)

Series 6000 / ECB•S Grade VI Safes

(Superior to the overall security of UL listed TRTL-30x6 safes)

Standard, Unique & Advanced Features Provide Real Security Solutions

- ECB•S certified grade IV, V and VI burglary protection with equal protection on all six sides
- Certified explosive protection (EX)
- Certified fire protection for paper documents – 1-hour 350 °F
- Eight standard models designed to protect diamonds and colored stones, jewellery and watches, precious metals, coin, and other valuable collections, cash, negotiable securities, legal, financial and highly classified documents
- Advanced protection. The body of the safe is constructed with torch and drill resistant armour cast into one piece (encapsulated in an outer and inner steel body) for greater protection against attack. Differing security levels are achieved within the range by the use of increasingly resilient barrier materials. The doors are constructed using the same barrier materials together with the inclusion of additional protection over the locking areas.
- Boltwork. Four-way engagement with 32mm moving bolts extending from 3 sides of the door that secure the door effectively into the body. With up to 12 bolts, the 3-way moving boltwork provides effective defense against attacks. Specific anti-explosive devices protect the boltwork against explosion break-in.
- UL Listed Group 1 manipulation-resistant combination lock and high-security key lock
- Tempered glass plate activated relocking devices
- Super-lightweight models allow safes with up to 100% greater storage capacity (than comparable UL TRTL-15x6 and TRTL-30x6 safes) to be transported in elevators in high rise buildings
- Unique “secured-in-place” shelf design provides additional protection during burglary attacks. *(Also, reinforced shelves are an available option for all models except 2422-13EX.)*
- Unique hinge design allows complete straight-in access width when the doors are opened 90 degrees
- Two double door models with up to 39.5 cubic feet of storage capacity fit through standard 2’-6” doorways
- Custom interiors can be provided: drawers and pull-out shelves with full extension slides, private and depository compartments, etc
- Right and left swing models available
- All safes are prepared to be anchored to the floor



Chubb safes
Trusted the world over.

TORCH, TOOL, EXPLOSIVE
AND FIRE PROTECTION

Product Specifications

Basic Dimensions (inches/mm)

Model	Inside Dimensions			Outside Dimensions				Overall Depth (OD)	Adjustable Shelves
	Height (h)	Width (w)	Depth (d)	Height (H)	Width (W)	W90	Depth (D)		
2422-13EX	24.4/620	22/560	12.6/320	31.1/790	28.75/730	32.75/832	21/533	24.3/617	2
3022-16EX	29.5/750	22/560	15.75/400	36.2/920	28.75/730	32.75/832	24.2/615	27.45/697	2
3022EX	29.5/750	22/560	19.7/500	36.2/920	28.75/730	32.75/832	28/711	31.375/797	2
4322EX	43.3/1100	22/560	19.7/500	50/1270	28.75/730	32.75/832	28/711	31.375/797	3
5125EX	51.2/1300	25.2/640	19.7/500	57.875/1470	31.9/810	35.9/912	28/711	31.375/797	3
6628EX	66.1/1680	28/711	19.7/500	72.83/1850	34.7/880	38.7/983	28/711	31.375/797	5
6643EX	66.1/1680	42.5/1080	19.7/500	72.83/1850	49.2/1250	57.2/1453	28/711	31.375/797	5
6652EX	66.1/1680	52.4/1331	19.7/500	72.83/1850	59/1499	67/1702	28/711	31.375/797	5

Capacities and Weights *

Model	Storage Capacity (Cu. Ft./litres)	Series 4000 – Grade IV		Series 5000 – Grade V		Series 6000 – Grade VI	
		Body Weight (lb./kg.)	Total Weight (lb./kg.)	Body Weight (lb./kg.)	Total Weight (lb./kg.)	Body Weight (lb./kg.)	Total Weight (lb./kg.)
2422-13EX	3.9/111	917/416	1235/560	995/451	1312/595	1060/481	1400/635
3022-16EX	5.9/168	1158/525	1533/695	1257/570	1632/740	1343/609	1742/790
3022EX	7.4/210	1334/605	1709/775	1445/655	1819/825	1541/699	1940/880
4322EX	10.9/308	1702/772	2216/1005	1857/842	2370/1075	1993/904	2535/1150
5125EX	14.7/416	2024/918	2700/1225	2212/1003	2889/1310	2377/1078	3087/1400
6628EX	21.1/598	2569/1165	3506/1590	2800/1270	3737/1695	3010/1365	3990/1810
6643EX	32.0/906	2941/1334	4541/2060	3239/1469	4840/2195	3515/1594	5181/2350
6652EX	39.5/1119	3420/1551	5247/2380	3762/1706	5590/2535	4070/1846	5975/2710

* Weights without packing and interior fittings

Single Door Models – Door Swing Projections, Overall and Access Dimensions

Single Door Models (inches/mm)

Model	OW	W90	OD	ah	w	aw	W180	D90	D1
2422-13EX	29.75/756	32.75/832	24.3/617	22.5/572	22/560	20/508	55.9/1420	47.44/1205	16.1/409
3022-16EX	29.75/756	32.75/832	27.45/697	27.64/702	22/560	20/508	55.9/1420	50.6/1285	19.3/490
3022EX	29.75/756	32.75/832	31.375/797	27.64/702	22/560	20/508	55.9/1420	54.53/1385	23.25/590
4322EX	29.75/756	32.75/832	31.375/797	41.8/1062	22/560	20/508	55.9/1420	54.53/1385	23.25/590
5125EX	32.9/836	35.9/912	31.375/797	49.3/1233	25.2/640	23.2/589	62.2/1580	57.7/1465	23.25/590
6628EX	35.25/895	38.7/983	31.375/797	64.25/1632	28/711.2	26/660	67.7/1720	60.4/1535	23.25/590

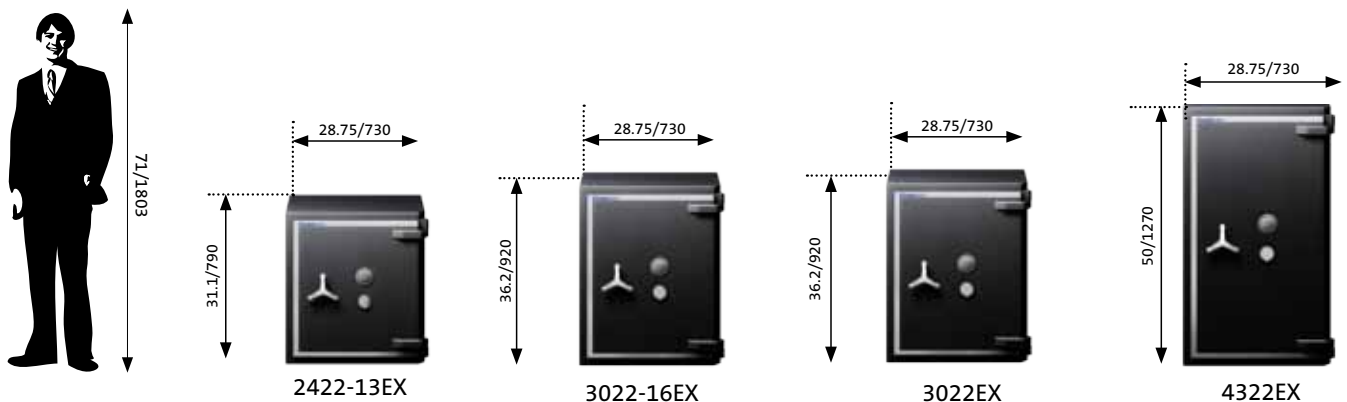

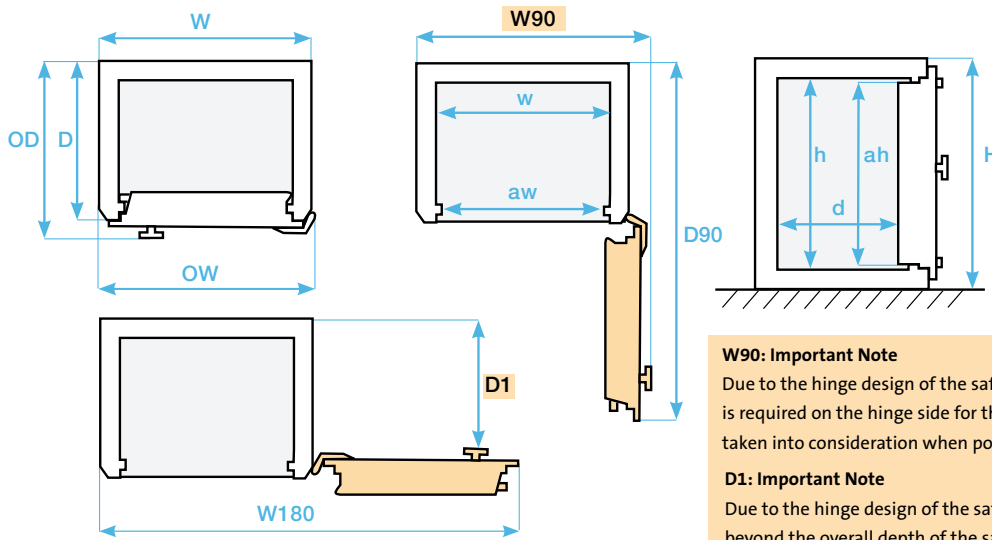

W90: Important Note
 Due to the hinge design of the safe, an additional 4" (100mm) of clear width is required on the hinge side for the door to be opened to 90°. This should be taken into consideration when positioning the safe.

D1: Important Note
 Due to the hinge design of the safe, when the door is open 180° it recesses beyond the overall depth of the safe by up to 8" (200mm). This should be taken into consideration when positioning the safe.

Double Door Models – Door Swing Projections, Overall and Access Dimensions

Double Door Models (inches/mm)

Model	OW	W90	OD	ah	w	aw	WL180	WR180	W180	DL90	DR90	D1
6643EX	51.2/1300	57.2/1453	31.375/797	64.25/1632	42.5/1080	40.63/1032	76.375/1940	74/1880	101.2/2570	52.125/1324	54.5/1384	23.25/590
6652EX	61/1549	67/1702	31.375/797	64.25/1632	52.4/1331	50.5/1283	89.375/2270	90.5/2299	120.875/3070	59/1499	57.625/1464	23.25/590

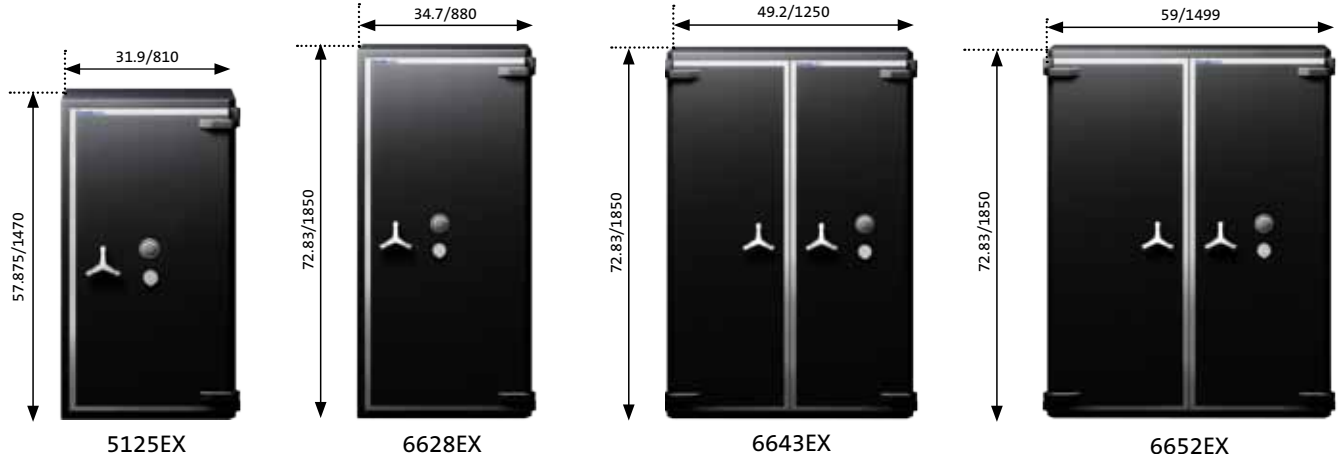
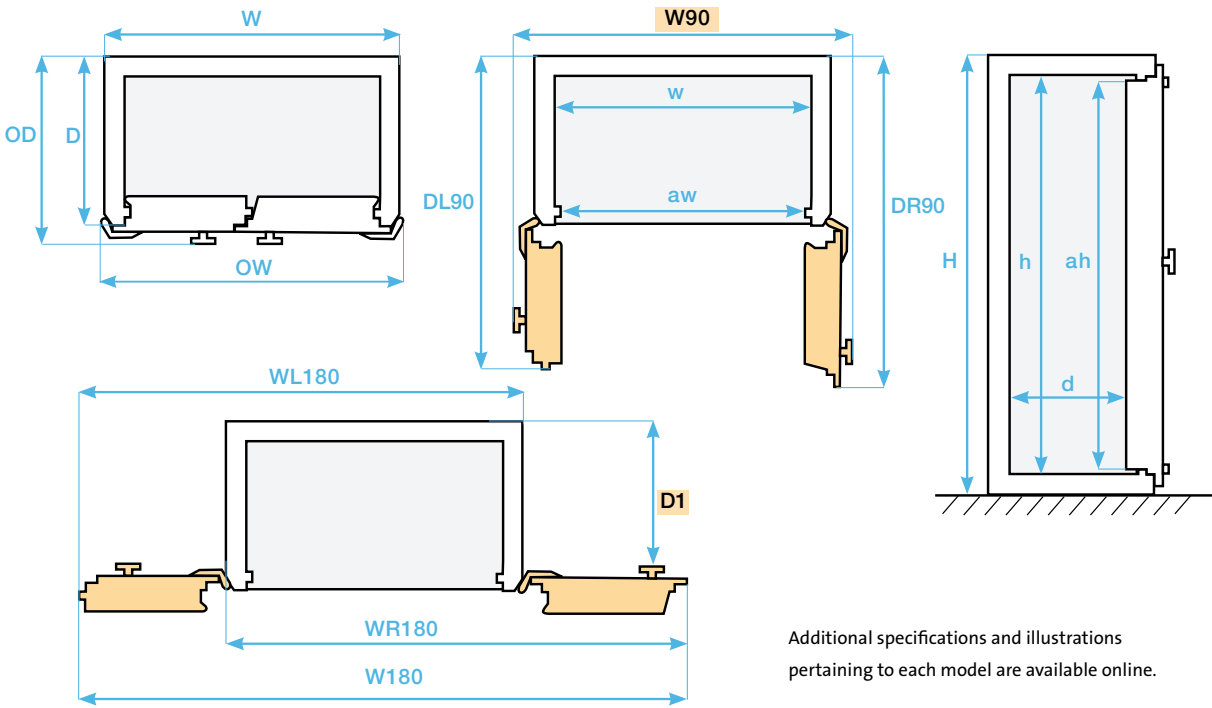

Lock Options

- A selection of ECB•S approved electronic and mechanical locks are available as substitutes for the standard locking arrangement.
- A third lock can be supplied (if required).
- An internal electronic or mechanical timelock can be supplied for additional security.

Grade IV (Series 4000) & Grade V (Series 5000)

- At least two EN 1300 Grade B locks must be fitted as standard. Many UL listed (and USA service supported) locks are among the approved locks. Please inquire for more details.

Grade VI (Series 6000)

- At least two EN 1300 Grade C locks must be fitted as standard. Many UL listed (and USA service supported) locks are among the approved locks. Please inquire for more details.

Testing and Certification



Burglary Certifications: Grades IV, V, and VI EN 1143-1 (ECB•S)

A range of tools typically used in burglary attempts were used to test the level of resistance, from basic equipment, such as hammers and simple drills, to sophisticated thermal and electrical equipment, such as oxyacetylene torches and disc cutters.



Explosives Certification: Grades IV EX, V EX and VI EX, EN 1143-1 (ECB•S)

The Chatwood Certified Series has also been approved for resistance against explosives – a particularly high level of protection for your valuables.



Fire Certification: EN 15659 LFS 60 (ECB•S)

The Chatwood Certified Series will protect paper documents from the effects of a severe fire for at least one hour. In order to qualify for this certification, the safe was placed in a furnace, and over the course of the test, was heated up to a temperature of 1700 °F.

About ECB•S

ECB•S is the most widely recognized certification mark in Europe, is relied upon by the highest risk insurers, including Lloyds agencies, and now by USA insurance companies. ECB•S confirms a product's compliance with the strictest of European standards for burglary and fire protection. No other safe and vault certification organization exists today (throughout the world) with such a thorough and comprehensive program of performance testing and auditing.

Safes are certified in grades in accordance with the EN 1143-1 burglary protection standards. Fire resistance testing is conducted for specific periods of time, for the protection of paper or computer media, in accordance with the EN 1047-1 and EN 15659 standards.

Authorized Dealer

EMPIRESAFE

Empire Safe Company, Inc.
New York, NY

Tel 212-684-2255 Toll-Free 800-543-5412 Fax 212-684-5550

Website: www.empiresafe.com

Email: info@empiresafe.com

Chubbsafes
Trusted the world over.

www.chubbsafes.com

*Chubb' is owned by Chubb plc and is a registered trademark used under license